



6 MONTHS 50,000 MILES Powertrain Coverage

Drive with Confidence: Protect Against Unexpected Repairs

BASELINE COVERAGE	Coverage includes Engine, Turbos, Fuel injectors, Fuel pump, Water pump, ECM, and Aftertreatment	\$2,629
OPTIONAL COVERAGE	Auxiliary Power Unit \ APU Transmission & Rear Differential	+ \$250 + \$250
COVERAGE LIABILITY (LOL)	Engine Turbo Fuel Injectors/Pump, Water Pump, ECM Aftertreatment Auxiliary Power Unit (APU) Transmission / Rear Differential, EACH Aggregate Limit	\$22,500 \$7,500 \$5,000 \$7,000 \$4,000 \$7,500/\$7,500 \$30,000/ACV*
TERMS & CONDITIONS	<ul style="list-style-type: none"> ▪ Heavy duty class 8 ▪ 180 days/50,000 miles term ▪ \$350 deductible ▪ Model year <10 years ▪ Starting mileage <900,000 miles ▪ \$250 Surcharge for MY 2014 + or start miles >600,000 	

> Prevent **Costly** Repair Surprises

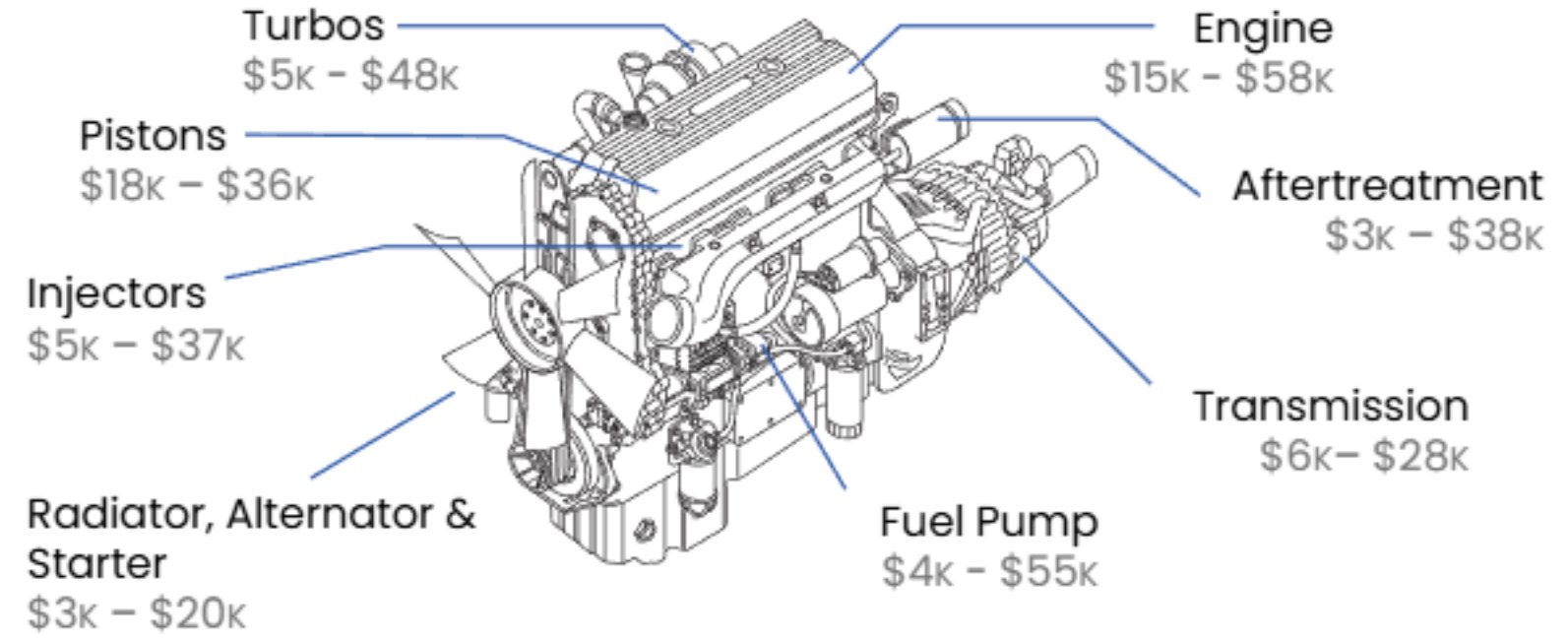

VALUE PACK – Included in the contract coverage

Engine **INCLUDED**

- Camshaft, Cam bearings & Cam followers
- Connecting rods, Connecting rods bearings, Caps and cap screws
- Crankshaft
- Cylinder heads, block casting, head bolts, head gasket & liner
- Exhaust manifold & Flywheel housing
- Hydraulic lifters
- Intake manifold, intake and exhaust valve, valve guides & Injector cups
- Main bearings
- Oil pan, oil cooler and housing
- Oil pump housing, gears, pickup screen, pick up tube, pressure relief springs & pressure relief valves
- Pistons, piston rings & piston oil cooling jets
- Pushrods, rocker arms & shafts
- Thermostat housing
- Thrust washers
- Timing gears, cover and housing
- Valve cover, retainers, seats, springs & keepers (locks)
- Vibration dampener
- Wrist pins

Engine Fuel Injectors & More (Critical Components) **INCLUDED**

- Complete Injector
- Fuel injector pump & hard lines
- Fuel Pump & water pump
- Engine Control Module (ECM)

Turbo (Critical Components) **INCLUDED**

- Bearings
- Internal Variable Vane Assembly
- Turbine and Turbine Shaft
- Turbo Actuator

Towing reimbursement (3 instances) **INCLUDED**

Transmission & Rear Differential **OPTION**

- | | |
|--|--|
| <p>Transmission:</p> <ul style="list-style-type: none"> • Bands • Bearings • Blockers • Bushings • Control Module (TCM) • Drums • Gear Sets • Governor • Oil Pump & Shafts • Shift forks • Speed Sensor • Synchronizers • Thrust Washers • Torque Converter • Valve Body | <p>Differential</p> <ul style="list-style-type: none"> • Axle Housing • Axle Shafts • Bearings • Bushings • Carrier Case • Gear Sets • Limited Slip Clutch Pack <p>Power divider includes:</p> <ul style="list-style-type: none"> • Bearings • Gears • Shafts • Shift Forks |
|--|--|

OPTION – Can be added as optional coverage

Aftertreatment **INCLUDED**

- Aftertreatment Electronic Control Module (ACM)
- Back Pressure Control Valve (BPV)
- Diesel Exhaust Fluid (DEF) Module
- DEF Injection Nozzle
- DEF Heater Control Relay
- DEF Dosing Module - Wiring Harness
- DEF Heated Lines (3)
- DEF Heater Coolant Control Valve
- DEF Heating Elements & Fittings (3)
- DEF Pump, Module & Tank
- DEF Solution Level/Temp Sensor
- Diesel Oxidation Catalyst (DOC) & DOC Doser injector
- Diesel Particulate Filter (DPF)
- DPF Air, Fuel, Coolant Lines
- DPF Air, Fuel, Manifold Assembly
- DPF Dosing Module
- Exhaust Gas Recirculation (EGR) Valves
- EGR Actuator, Coolers, Connecting Bellows & Clamps
- Exhaust Piping, Clamps, Gaskets and Throttle Valve
- Hydrocarbon Doser Injector (HC Doser, 7th Injector, ARD, AHI Module)
- Hydrocarbon Doser Valve - Air, Fuel, and Coolant Lines; and Inline Air Filter
- Hydrocarbon Doser Valve (Voss Valve)
- Selective Catalytic Reduction (SCR) Catalyst
- SCR Decomposition Pipe and Pipe Elbows
- Sensor, BPV Pressure
- Sensor, Delta P (DPF Pressure/DPF soot/particulate level sensor)
- Sensor, DOC Inlet Pressure
- Sensors, DOC (Post/Pre) Temp
- Sensor, DPF Air Supply Pressure
- Sensors, DPF Back Pressure & DPF Fuel Pressure
- Sensor, Lambda (O2 Sensor)
- Sensor, NOx (2)
- Sensor, Pressure After Exhaust Throttle Valve
- Sensors, SCR (Post/Pre) Temp
- Wiring Harness - Emission Systems (including overlay)

APU **OPTION**

Internally lubricated hard parts of engine components: cam followers; camshaft and cam bearings; connecting rod bearings & rods; constant velocity valve; crankshaft; hydraulic lifters; injectors; intake and exhaust valves and guides; main bearings; oil pan, pump gears, housing, pick up screen & tube; pressure relief springs and valves; pistons & oil cooling jets & piston rings, and more.

Repair costs based on NTP / Premium 2000 claims data. See contract for complete coverage and conditions © 2025 National Truck Protection Co., Inc.